

Alcatel OAW-AP80M Access Point

Installation Guide

Copyright

Copyright © 2007 Alcatel Internetworking, Inc. All rights reserved.

Specifications in this manual are subject to change without notice.

Originated in the USA.

Trademarks

AOS-W, Alcatel 4308, Alcatel 4324, Alcatel 6000, Alcatel 41, Alcatel 60/61/65, Alcatel 70, and Alcatel 80 are trademarks of Alcatel Internetworking, Inc. in the United States and certain other countries.

Any other trademarks appearing in this manual are the property of their respective companies.

Legal Notice

The use of Alcatel Internetworking Inc. switching platforms and software, by all individuals or corporations, to terminate Cisco or Nortel VPN client devices constitutes complete acceptance of liability by that individual or corporation for this action and indemnifies, in full, Alcatel Internetworking Inc. from any and all legal actions that might be taken against it with respect to infringement of copyright on behalf of Cisco Systems or Nortel Networks.

Contents

<i>Chapter 1</i>	Getting Started	1
	Package Checklist.....	1
	Additional Items—Supplied Separately.....	2
<i>Chapter 2</i>	Introduction	3
	Overview.....	3
	Front View.....	4
	Rear View.....	6
	The Alcatel AP Setup Process.....	7
	System Configuration.....	7
<i>Chapter 3</i>	AP Deployment	9
	Mounting the OAW-AP80M.....	9
	Mounting the AP.....	10
	Using the Pole-Mounting Bracket.....	10
	Using the Wall-Mount Bracket (Optional Part).....	13
	Mount and Connect External Antennas.....	14
	Connecting the AP.....	15
	Connecting the Ground Wire.....	15
	Connect Ethernet Cable to the AP.....	16
	Connect External Antennas.....	17
	Connect the Power Injector.....	18
	Orient the Antennas.....	20
<i>Appendix A</i>	Troubleshooting	21
	Accessing the AP Support Prompt.....	21
	Remote Telnet Connection.....	21
	AP Support.....	22
	Access Levels.....	22
	User Commands.....	22
	Privileged Commands.....	22
	Resetting the Access Point to Factory Defaults.....	23
<i>Appendix B</i>	Port Specifications	25
	Eight-Pin DIN Ethernet Connector Pinout.....	25
	Eight-Pin DIN to RJ-45 Cable Wiring.....	25

Power over Ethernet Injector Module 10/100BASE-TX Pin
Assignments..... 26

Appendix C

Product Specifications 27

Product Features 27

 Ethernet Compatibility..... 27

 Power Over Ethernet..... 27

 Radio Characteristics..... 27

Compliance 28

Compliance 29

 United States 29

 Canada..... 30

 Japan 31

 Korea..... 31

 Europe 31

 Taiwan 32

OAW-AP80M Detachable Antennas 37

Proper Disposal of Alcatel Equipment 38

 Waste of Electrical and Electronic Equipment..... 38

 European Union RoHS..... 38

 China RoHS 39

Related Documents..... 39

Contacting Alcatel..... 40



CAUTION: Alcatel Access Points are radio transmission devices and as such are subject to governmental regulations. Alcatel Access Points are sold through authorized, non-retail, distribution channels and are required to be deployed by a Professional Installer / Qualified Network Administrator. The professional installer responsible for the configuration and operation of Access Points must ensure the installation complies with local regulations, frequencies, channels, and output power.

Before installing your OAW-AP80M Access Point, please ensure you have the following:

Package Checklist

- One Alcatel OAW-AP80M Access Point
- One Pole Mount Hardware Kit
- One Installation Guide (this document)
- One Auto-sensing 110/240VAC to 48VDC Power over Ethernet Injector suitable for use with Alcatel OAW-AP80M Access Point (**indoor use only**)
- One outdoor Ethernet cable—50 meters (164 feet) 8-pin DIN to 10/100Base-T RJ-45

Inform your supplier if there are any incorrect, missing or damaged parts. If possible, retain the carton, including the original packing materials. Use them to repack the product in case there is a need to return it.

NOTE: The Alcatel OAW-AP80M Access Point requires external antennas, which are sold separately. (See [Table C-4, “Detachable Antennas,”](#) on page 37 for a list of antennas.)

Additional Items—Supplied Separately

The following items are available for use with the OAW-AP80M and are sold separately:

- Detachable antenna (required)
See [Table C-4, "Detachable Antennas,"](#) on page 37.
- Wall Mount Hardware Kit (AP-80-MNT)
- Antenna Interface Lightning Arrester Hardware (AP-LAR-1; required for warranty) The lightning surge arrester for the OAW-AP80M Access Point is a single, in-line lightning arrester with N-type Male to N-type Female interface. Supports RF frequency pass through of 2Ghz – 6Ghz.
- Antenna extension cable—3 meter (10 foot) long, low-loss LMR 400 antenna extension cable (part number AP-CBL-1) for use with OAW-AP80M Access Points. Includes OAW-AP80M N-Type Female interface to N-Type Male on antenna interface.

Check with your Alcatel sales representative for the availability of optional items.

Overview

The Alcatel OAW-AP80M Access Point is part of a comprehensive wireless network solution. The device works in conjunction with the OmniAccess WLAN Switch and can act as a wireless access point or air monitor.

As a wireless Access Point (AP), the Alcatel OAW-AP80M Access Point provides transparent, secure, high-speed data communications between wireless network devices (fixed, portable, or mobile computers with IEEE 802.11a (country regulatory domain permitting) or IEEE 802.11b/g wireless adapters) and the wired LAN.

As a wireless Air Monitor (AM), a feature unique to OmniAccess products, the Alcatel OAW-AP80M Access Point enhances wireless networks by collecting statistics, monitoring traffic, detecting intrusions, enforcing security policies, balancing wireless traffic load, self-healing coverage gaps, and more.

NOTE—Installing the OAW-AP80M requires setting the antenna gain, which requires professional training. The OAW-AP80M installer must be trained to perform this configuration.

Front View

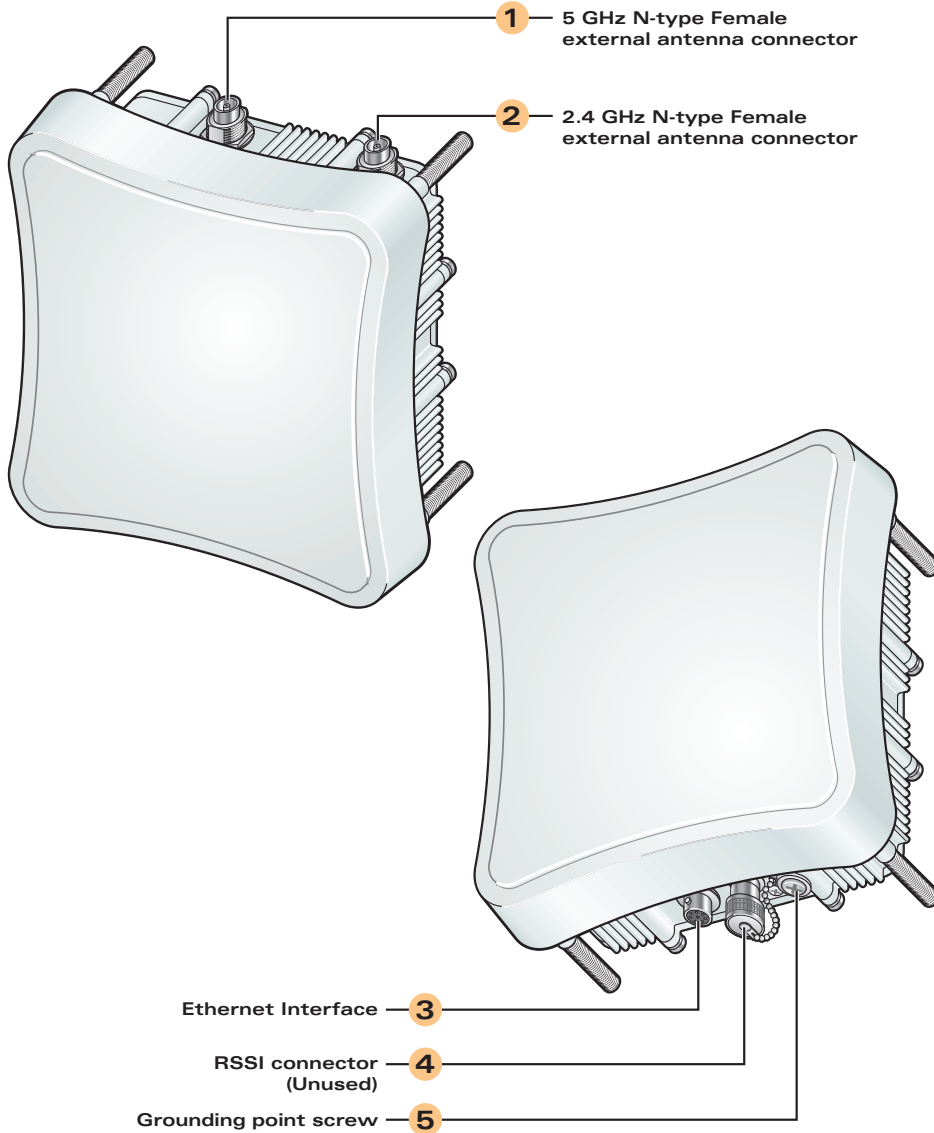

- 1** 5 GHz External Antenna Interface (5 GHz, N-Type, female)
- 2** 2.4 GHz External Antenna Interface (2.4 GHz, N-Type, female)

3 Fast Ethernet Interface Port

The wireless Access Point has one 10BASE-T/100BASE-TX 8-pin DIN port that connects to the power injector module using the included Ethernet cable. The Ethernet port connection provides power to the wireless Access Point as well as a data link to the local network.

The wireless Access Point appears as an Ethernet node and performs a bridging function by moving packets from the wired LAN to the remote end of the wireless Access Point link.

NOTE—The power injector module does not support Power over Ethernet (PoE) based on the IEEE 802.3af standard. The wireless Access Point unit must always be powered on by being connected to the power injector module.

4 RSSI Connector

Not used.

5 Grounding Screw

Even though the wireless Access Point includes its own built-in lightning protection, it is important that the unit is properly connected to ground. A grounding screw is provided for attaching a ground wire to the unit.

NOTE—The OAW-AP80M requires lightening protection. Alcatel recommends the use of lightening arresters. Failure to provide protection from lightening strikes will void the warranty for this product.



WARNING: Do not work on the OAW-AP80M or connect or disconnect cables during periods of lightening activity.

See “[Product Specifications](#)” for port and cable specifications.

Rear View

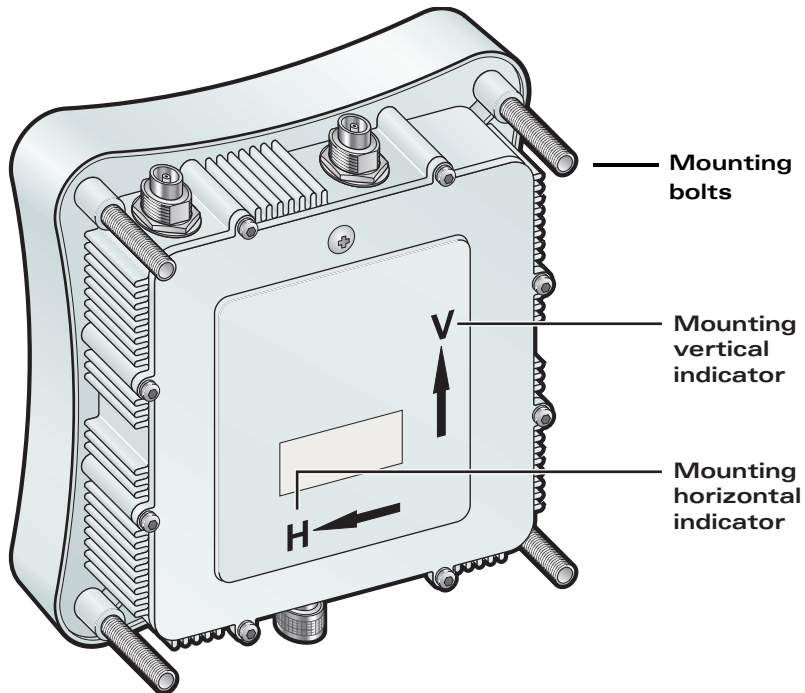

- Mounting bolts (4)
- Vertical mounting indicator
- Horizontal mounting indicator

See "[Product Specifications](#)" for port and cable specifications.

The Alcatel AP Setup Process

Setting up an Alcatel AP typically consists of four stages:

1. **WLAN Planning**—The administrator determines how many Alcatel APs will be needed for their wireless network strategy and where they will be deployed. This can be easily accomplished using Alcatel’s automated RF Plan site-survey software (available separately).
2. **AP Provisioning**—Provisioning provides each Alcatel AP with initial settings that allow it to locate the host OmniAccess WLAN Switch. Depending on the network topology and services, AP provisioning can be performed manually for each AP or plug-and-play for batches of APs.

AP provisioning is discussed in [“AP Provisioning”](#).

3. **AP Deployment**—Once provisioned, each AP can be physically installed at its intended place of operation.

AP deployment is covered in [“Mounting the OAW-AP80M”](#).

4. **AP Configuration**—The administrator defines the operational behavior for each Alcatel AP, such as RF characteristics and security features.

For AP configuration information, refer to the *AOS-W User Guide*.

System Configuration

The wireless Access Point receives power through a shielded Ethernet cable (special 8-pin DIN connector type at AP) to connect to the non-802.3af-compliant Power over Ethernet injector module. The power injector module provides two RJ-45 Ethernet ports, one for connecting to the wireless Access Point (AP), and the other for connecting to a local LAN switch (ENET).

At each location where a unit is installed, it must be connected to the local network using the power injector module.

The Power over Ethernet injector module port uses an MDI (that is, internal straight-through) pin configuration. You can therefore use straight-through twisted-pair cable to connect this port to most network interconnection devices such as a switch or router that provide MDI-X ports. However, when connecting the access point to a workstation or other device that does not have MDI-X ports, you must use crossover twisted-pair cable.

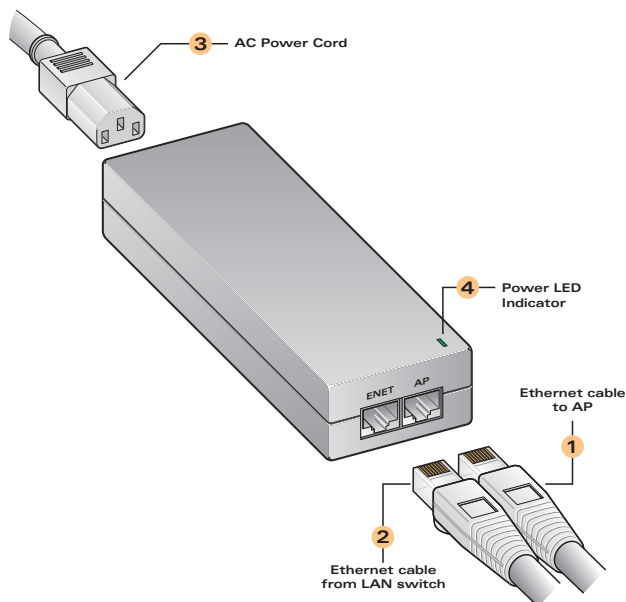

1 AP Connector

Ethernet cable from the Alcatel OAW-AP80M Access Point

2 ENET Connector

Ethernet cable from the LAN switch

3 AC Power Cord

AC power cord for the PoE injector

4 LED

LED indicator illuminates steady green when power is supplied to injector. It is off when there is no power supplied to the injector.

The OAW-AP80M Access Point does not have a power switch. It is powered on when its Ethernet port is connected to the power injector module, and the power injector module is connected to an AC power source. The power injector includes one LED indicator that turns on when AC power is applied.

The power injector module automatically adjusts to any AC voltage between 100-240 volts at 50 or 60 Hz. No voltage range settings are required.



WARNING: The power injector module is designed for indoor use only. Never mount the power injector outside with the OAW-AP80M Access Point unit.

Mounting the OAW-AP80M



WARNING: The installation of outdoor-rated Access Points, antennas or ancillary equipment should only be performed by trained personnel. Do NOT attempt to install an Access Point on an elevated building, mast or pole by yourself or without the use of the appropriate safety equipment

The OAW-AP80M Access Point is designed to be deployed outdoors, exposed to the elements (extreme sunshine, rain, snow - hot and cold climates) and mounted on a wall, pole or mast.

The OAW-AP80M indoor-rated Power over Ethernet injector must be deployed indoors, or within an enclosure protecting it from the elements.

The OAW-AP80M Access Point is supplied complete with its own mounting hardware kit for attaching the unit to a 1.5" to 2" diameter steel pole or tube or as part of a radio mast or tower structure.

Physical installation of the OAW-AP80M Access Point involves the following steps:

1. Mount the unit on a wall, pole, mast, or tower using the mounting bracket.
2. Mount external antennas on the same supporting structure as the Access Point and connect them to the Access Point unit. .



CAUTION: The use of lightning arrester units, in-line or mast mounted, with the N-Type antenna interface is highly recommended, and if not used, may void product warranty.



CAUTION: Be sure that grounding is available and that it meets local and national electrical codes. For additional lightning protection, use lightning rods, lightning arrestors, or surge suppressors

3. Connect the grounding wire to the unit.
4. Connect the Ethernet cable to the unit.

5. Connect the power injector to the Ethernet cable, a local LAN network point and an AC power source.
6. Orient the antennas.

Mounting the AP

Using the Pole-Mounting Bracket

Perform the following steps to mount the unit to a 1.5 to 2 inch diameter steel pole or tube using the mounting bracket:

1. Always attach the bracket to a pole with the open end of the mounting grooves facing up.
2. Place the U-shaped part of the bracket around the pole and tighten the securing nut just enough to hold the bracket to the pole. (The bracket may need to be rotated around the pole during the alignment process.)

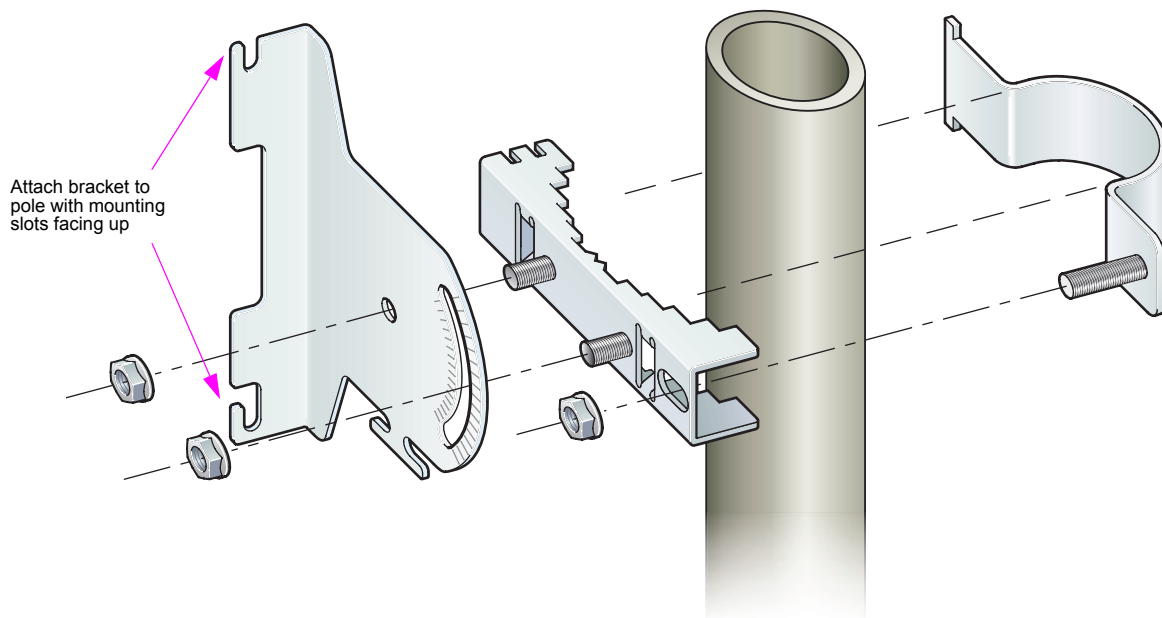

3. Use the included nuts to tightly secure the Access Point to the bracket. Be sure to take account of the antenna polarization direction; both antennas in a link must be mounted with the same polarization.

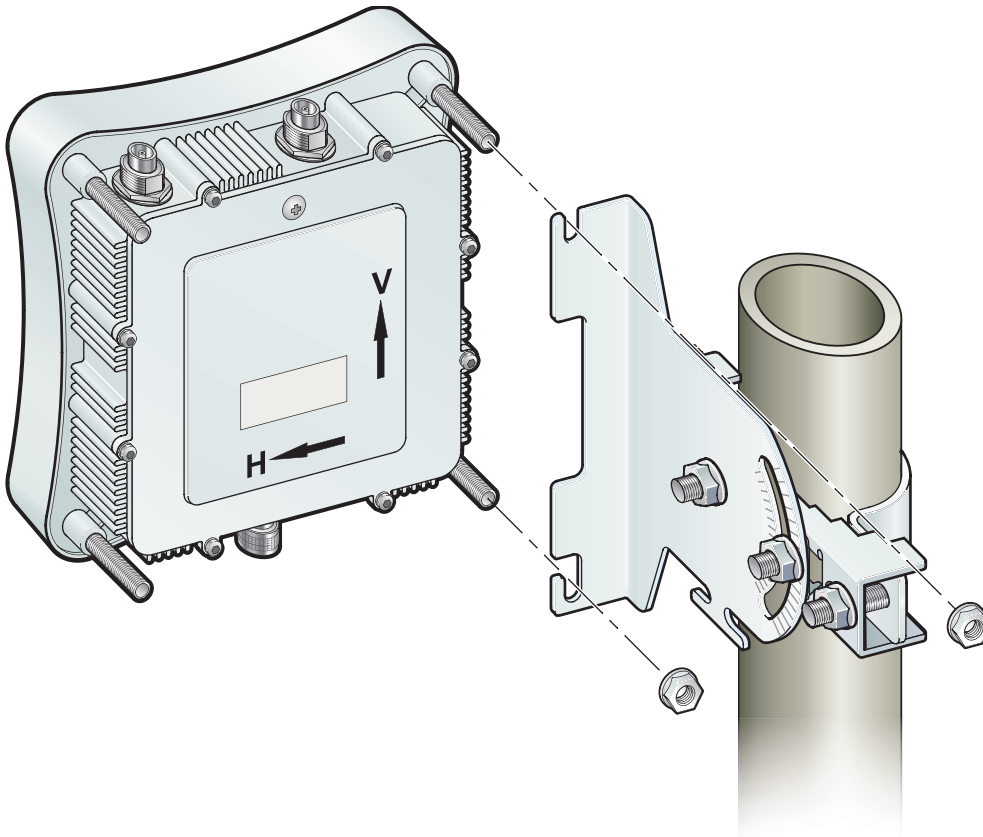

Mounting on Larger Diameter Poles

In addition, there is a method for attaching the pole-mounting bracket to a pole that is 2 to 5 inches in diameter using an adjustable steel band clamp (not included in the kit). A steel band clamp up to 0.5 inch (1.27 cm) wide can be threaded through the main part of the bracket to secure it to a larger diameter pole without using the U-shaped part of the bracket. This method is illustrated in the following figure.

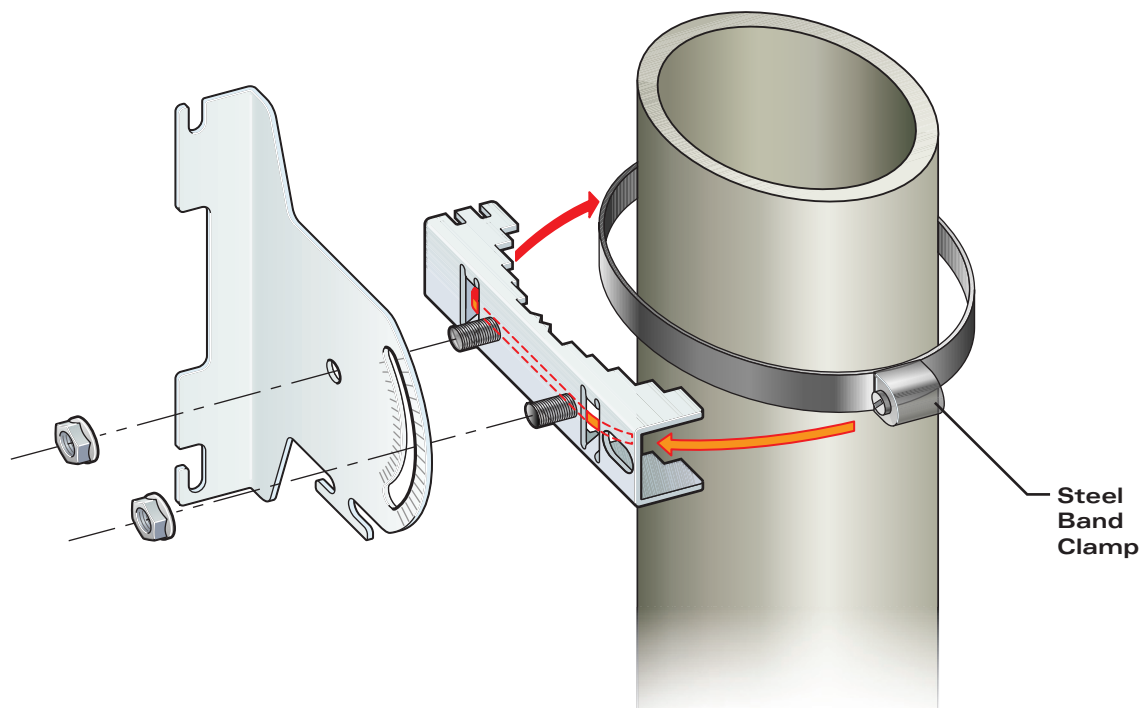

Using the Wall-Mount Bracket (Optional Part)

Use the wall-mount bracket for attaching the OAW-AP80M to a wall surface. For hollow walls, use anchors. For solid walls, use the appropriate screws. This method is illustrated in the following figure.

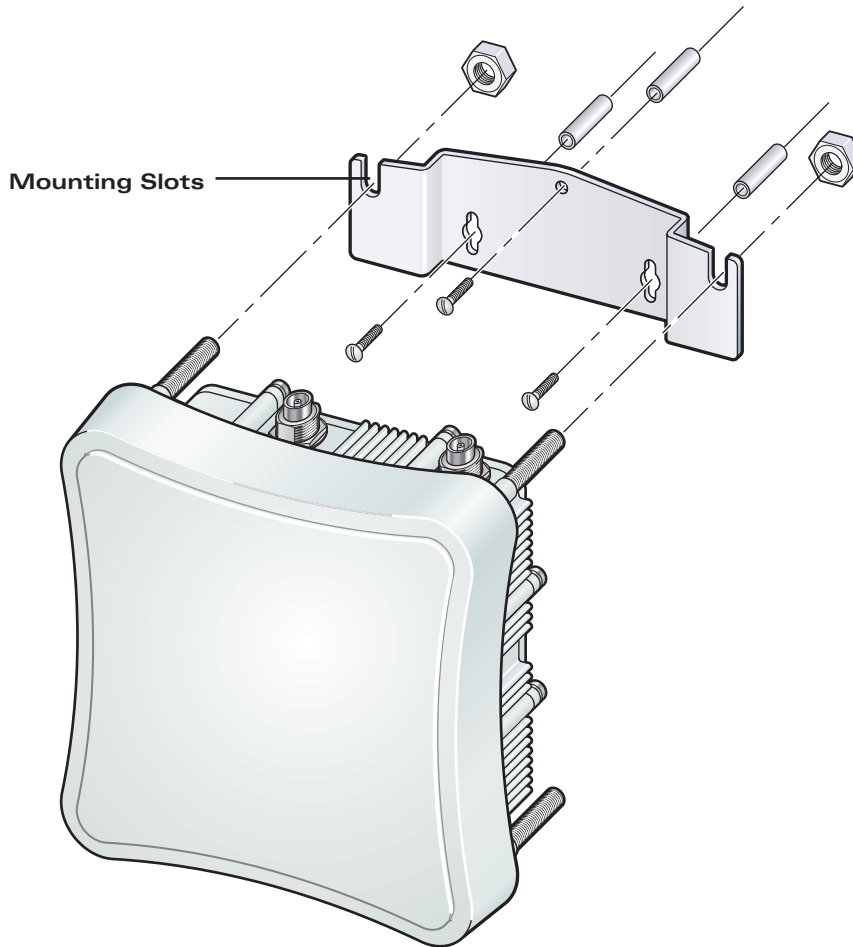

Mount and Connect External Antennas

Physically mount detachable antennas in their desired location, preferably to the same supporting structure as the Access Point, within 3 meters (10 feet) distance, using the bracket supplied in the antenna.

Connect the antenna to the Access Point's N-type Female connector using the RF coaxial cable provided with the antenna.

Apply weatherproofing tape to the antenna connectors to help prevent water entering the connectors.

When no antenna is connected to the N-Type interface, the waterproof interface boot should remain installed to protect the interface from the elements.



WARNING: The Antenna Lightning Arrester N-Type (AP-LAR-1) is available as a separately orderable part. Damage to the OAW-AP80M caused by lightening is not covered by the warranty if the Lightning Arrester is not used or is not properly installed.

Connecting the AP

Connecting the Ground Wire

Attach an electrical safety grounding wire to the electrical ground point on the access point.

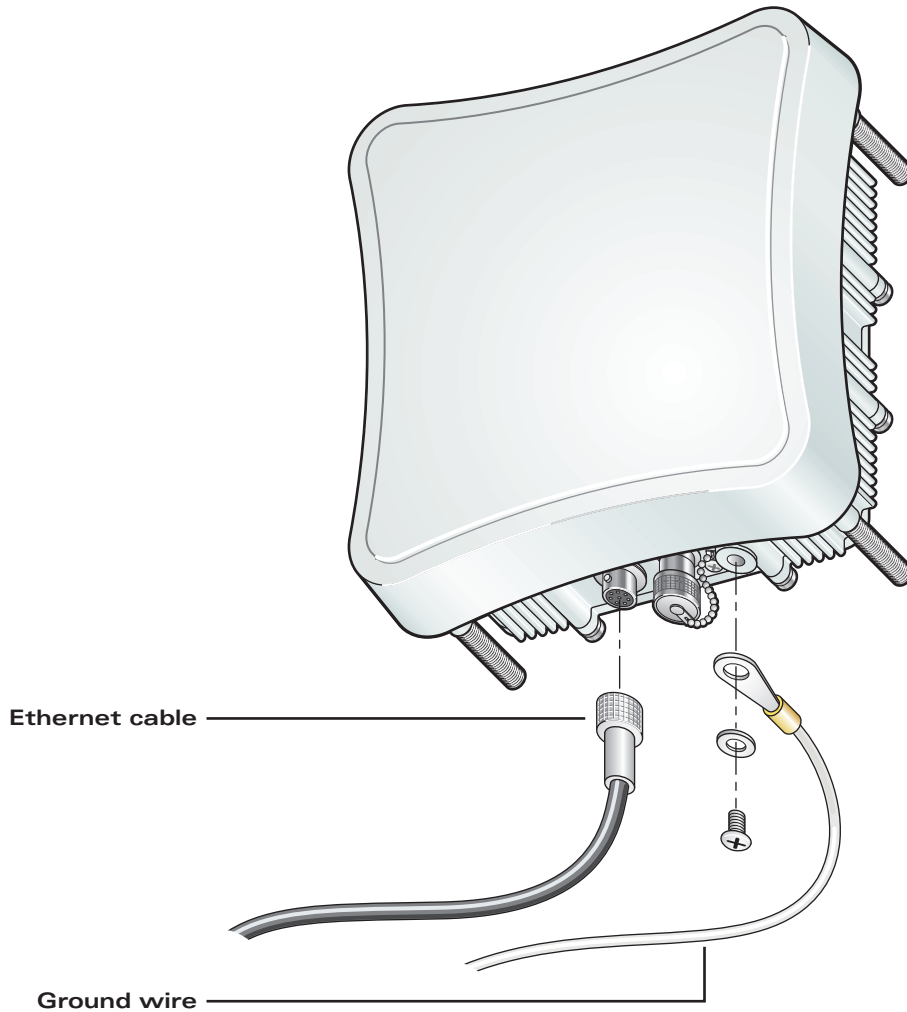

Connect Ethernet Cable to the AP



CAUTION: Be sure that grounding is available and that it meets local and national electrical codes. For additional lightning protection, use lightning rods, lightning arrestors, or surge suppressors

1. Attach the Ethernet cable to the Ethernet port on the wireless Access Point. (See figure above.)

NOTE: The Ethernet cable included with package is 50 meters (164 feet) long. Use the connector pinout information in Appendix B.

NOTE: The combined cable lengths connecting the store-and-forward Ethernet device, the PoE injector, and the AP must not exceed 90 meters (295 feet).

2. For extra protection against rain or moisture, apply weatherproofing tape (not included) around the Ethernet connector.
3. Be sure to ground the unit with an appropriate grounding wire (not included) by attaching it to the grounding screw on the unit.



CAUTION: Be sure that grounding is available and that it meets local and national electrical codes. For additional lightning protection, use lightning rods, lightning arrestors, or surge suppressors

Connect External Antennas

If you are using external antennas, connect the RF Coax cabling from the external antenna to the appropriate N-type connector on the AP as illustrated below:

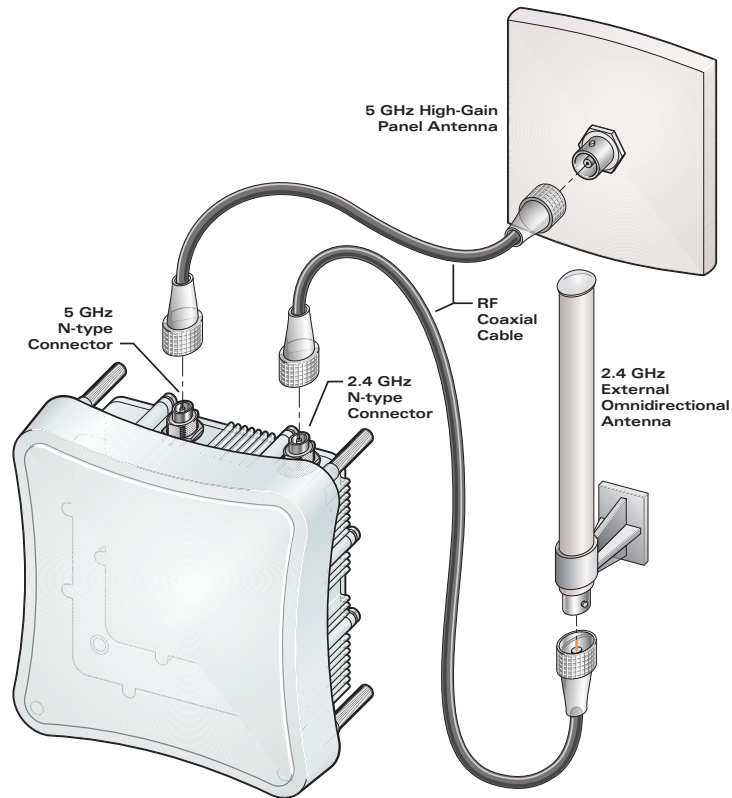

Connect the Power Injector



CAUTION: The Access Point's Ethernet port does not support Power over Ethernet (PoE) based on the IEEE 802.3af standard. Do not try to power the unit by connecting it directly to a network switch that provides IEEE 802.3af PoE due to the AP's maximum power draw requirement of 30 Watts. Always connect the unit to the correct Power over Ethernet injector module.



WARNING: The power injector module is designed for indoor use only. Never mount the power injector outside with the Access Point unit.

To connect the OAW-AP80M Access Point to a power source:

1. Connect the Ethernet cable from the wireless Access Point to the RJ-45 port labeled AP on the power injector.
2. Connect a straight-through unshielded twisted-pair (UTP) cable from a local LAN switch to the RJ-45 port labeled ENET on the power injector. Use Category 5 or better UTP cable for 10/100BASE-TX connections.

NOTE: The RJ-45 port on the power injector is an MDI port. If connecting directly to a computer for testing the link, use a crossover cable.

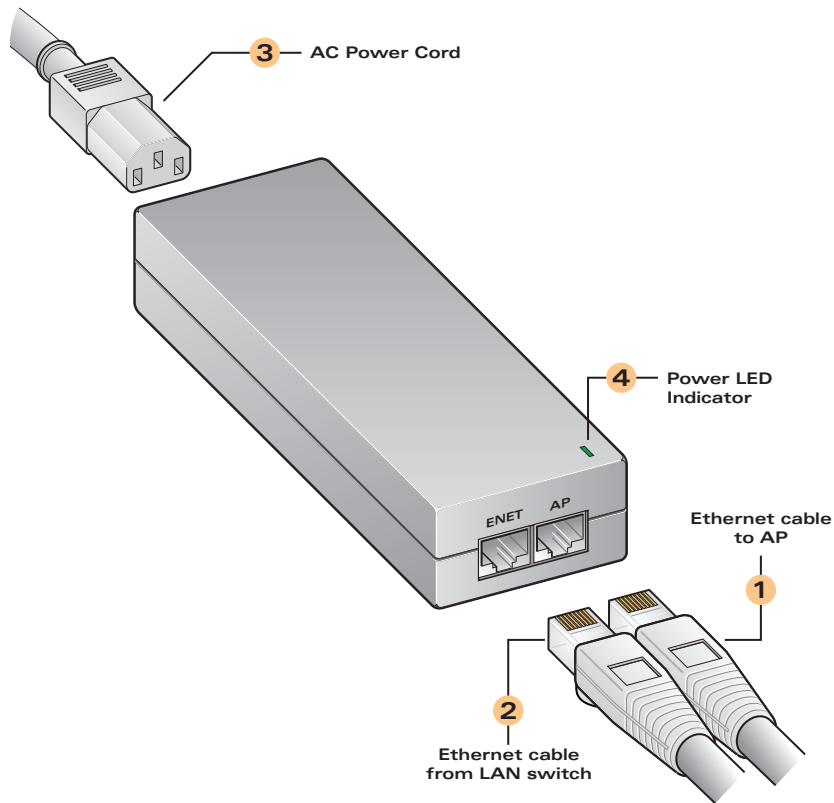

3. Insert the power cable plug directly into the standard AC receptacle on the power injector.
4. Plug the other end of the power cable into a grounded, 3-pin socket, AC power source.

NOTE: For International use, you may need to change the AC line cord. You must use a line cord set that has been approved for the receptacle type in your country.

5. Check the LED on top of the power injector to be sure that power is being supplied to the Access Point through the Ethernet connection.

Orient the Antennas

After the OAW-AP80M Access Point units have been mounted, connected, and their radios are operating, the antennas must be accurately aligned to ensure optimum performance on the Access Point links.

After provisioning and deployment, the Alcatel OAW-AP80M Access Point can be configured and managed through the OmniAccess WLAN Switch. However, the Alcatel OAW-AP80M Access Point includes built-in troubleshooting features for situations where the OmniAccess WLAN Switch commands are unable to diagnose AP problems.

This appendix describes using the built-in AP support prompt for troubleshooting.

Accessing the AP Support Prompt

Depending on your network topology, the built-in AP Support prompt can be accessed using using Telnet from a remote management station.

Remote Telnet Connection

If properly set up, the AP support prompt can be accessed remotely using Telnet. By default, this feature is turned off for security purposes and cannot be turned on using the AP interface.

Setting Telnet Access

Telnet access can only be changed from the OmniAccess WLAN Switch management interface. Log in to the OmniAccess WLAN Switch CLI using the `admin` account, access the configuration (`config`) prompt, and issue the following commands:

```
(alcatel) (config) # ap location <building>.<floor>.<device>  
(alcatel) (sap-config location b.f.d) # telnet {enable|disable}
```

Using Telnet to Connect

Use a Telnet client on your management workstation to connect to the Alcatel OAW-AP80M Access Point's individual IP address. The connection command may vary depending on the specific software used, but commonly appears as follows:

```
> telnet <Alcatel OAW-AP80M Access Point IP address>
```

When the connection is established, the AP support prompt (#) will be displayed.

AP Support

Access Levels

- User Access

User access is a low security level, featuring only the most basic commands. It is available without any additional login after the AP has booted.

- Privileged Access

Privileged-level access requires the privileged password (the same privileged password used on the OmniAccess WLAN Switch) to be entered using the user level `enable` command. The privileged access level is available only after the AP has successfully booted and synchronized with OmniAccess WLAN Switch.

User Commands

- `ping <host|IP address>`

Verify IP connectivity between the AP and the host address.

- `route`

Display the contents of the AP route table.

- `ifconfig`

Display the AP's IP address settings.

- `enable <privileged password>`

Access the AP Support privileged mode.

Privileged Commands

In addition to the user commands, the following commands are available upon successfully entering the privileged mode:

- `ps`
- `show [config|stats|version]`

NOTE: These commands should be used only as directed by Alcatel Customer Support.

Resetting the Access Point to Factory Defaults

In the event you need to reboot the Access Point with the configuration shipped from the factory, you must access and press the reset button. To access the reset button, remove the back of the OAW-AP80M case. The reset button is located on the system board next to the Ethernet port. To reset the OAW-AP80M configuration to factory default, press and hold down the reset button while power cycling the device.



CAUTION: Only properly trained personnel should perform this task. Furthermore, this procedure should be performed only in a staging facility. Do not perform a reset in the field.

Eight-Pin DIN Ethernet Connector Pinout

The Ethernet cable from the power injector connects to an 8-pin DIN connector on the OAW-AP80M Access Point. This IP67 8-pin male (pole) M12 circular DIN connector (with gold-plated (Au) contacts) is described below.

8-Pin DIN Ethernet Port Pinout	
Pin	Signal Name
1	Transmit Data plus (TD+)
2	Transmit Data minus (TD-)
3	Receive Data plus (RD+)
4	+48 VDC power
5	+48 VDC power
6	Receive Data minus (RD-)
7	Return power
8	Return power

Note: The "+" and "-" signs represent the polarity of the wires that make up each wire pair.

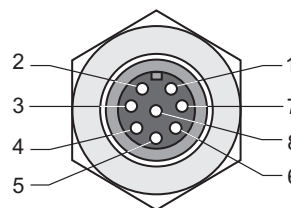

Eight-Pin DIN to RJ-45 Cable Wiring

The AP port to the Access Point's 8-pin DIN connector uses straight-through IEEE standards based Ethernet, illustrated in the diagram below. Use Category 5 or better UTP or STP cable and be sure to connect all four wire pairs.

NOTE: Make sure that the combined length of any wiring connection between the OmniAccess WLAN Switch and the PoE injector, and the PoE injector to the AP does not exceed 90 meters (295 feet).

NOTE: To construct a reliable Ethernet cable, always use the proper tools or ask a professional cable supplier to construct the cable.

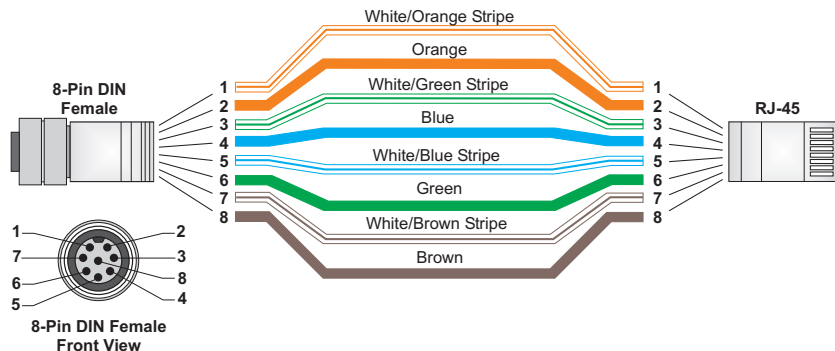

Power over Ethernet Injector Module 10/100BASE-TX Pin Assignments

Use unshielded twisted-pair (UTP) or shielded twisted-pair (STP) cable for RJ-45 connections: 100-ohm Category 3 or better cable for 10 Mbps connections, or 100-ohm Category 5 or better cable for 100 Mbps connections.

NOTE: Make sure that the combined length of any twisted-pair connection between the OmniAccess WLAN Switch and the PoE injector, and the PoE injector to the AP does not exceed 90 meters (295 feet).

The RJ-45 ENET port on the power injector is wired with MDI pinouts. This means that you must use crossover cables for connections to PCs or servers, and straight-through cable for connections to switches or hubs. However, when connecting to devices that support automatic MDI/MDI-X pinout configuration, you can use straight-through cabling.

10/100BASE-TX MDI and MDI-X Port Pinouts		
Pin	MDI-X Signal Name	MDI Signal Name
1	Receive Data plus (RD+)	Transmit Data plus (TD+)
2	Receive Data minus (RD-)	Transmit Data minus (TD-)
3	Transmit Data plus (TD+)	Receive Data plus (RD+)
6	Transmit Data minus (TD-)	Receive Data minus (RD-)
4,5,7,8	Not used	Not used

Note: The "+" and "-" signs represent the polarity of the wires that make up each wire pair.

Product Features

- Wireless dual-band transceiver
- Various antenna options (see [Table C-4](#))
- Protocol-independent networking functionality
- Supports IEEE 802.11a or IEEE 802.11b/g operation as an AP
- Supports IEEE 802.11a and IEEE 802.11b/g operation as an AM
- Seamless connectivity to wired LANs augment existing networks quickly and easily
- Can be centrally managed, configured, and upgraded through the OmniAccess WLAN Switch to take advantage of network changes and security improvements

Ethernet Compatibility

The Alcatel OAW-AP80M Access Point attaches to 10/100 Mbps Ethernet (FE) LAN segments that utilize 10Base-T/100Base-TX (twisted-pair) wiring. The device appears as an Ethernet node and performs a routing function by moving packets between the wired LAN and remote workstations on the wireless infrastructure.

Power Over Ethernet

The Alcatel OAW-AP80M Access Point supports non-standard Power Over Ethernet (POE) using the POE Injector Module, due to its 30W power draw requirement

Radio Characteristics

The Alcatel OAW-AP80M Access Point can be configured to support IEEE 802.11a or IEEE 802.11b/g operation as an AP, and supports both IEEE 802.11a and IEEE 802.11b/g operation as an AM (where allowed):

- 802.11a provides a high data rate and reliable wireless connectivity

802.11a operation uses a radio modulation technique known as Orthogonal Frequency Division Multiplexing (OFDM), and a shared collision domain (CSMA/CA). It operates in the 5 GHz Unlicensed National Information Infrastructure (UNII) band. Data is transmitted over a half-duplex radio channel operating at up to 54 Megabits per second (Mbps).
- 802.11b provides an alternative to wired LANs that can dramatically cut costs

802.11b operation uses the IEEE 802.11 High-Rate Direct Sequence (HRDS) specification, and a shared collision domain (CSMA/CA). It operates in the 2.4 GHz Industrial/Scientific/Medical (ISM) band. The ISM band is available worldwide for unlicensed use. Data is transmitted at speeds of up to 11 Mbps.

- 802.11g provides a high data rate and is backwards compatible with 802.11b.

802.11g operation uses OFDM and a shared collision domain (CSMA/CA). It operates in the 2.4 GHz Industrial/Scientific/Medical (ISM) band. The ISM band is available worldwide for unlicensed use. Data is transmitted at speeds of up to 54 Mbps.

Compliance

TABLE C-1 Access Point Compliance Certifications

Type	Applies to:	Standard
EMC	United States	FCC Part 15 Class B, DOC
	Canada	ICES-003 Class B
	Europe	CE, EN 301489
	Japan	VCCI Class B
	Rest of World	CISPR 22
RADIO	United States	FCC Part 15.247, 15.407
	Canada	RSS-210, RSS-Gen
	Europe	CE, R&TTE Directive, EN 300328, EN 301893
	Japan	TELEC:2.4 GHz, Channel 14, J52, W52, W53
	Korea	MIC, RRL
	Australia/New Zealand	C-TICK
	Taiwan	DGT LP0002
Safety	United States	UL 50 outdoor rating
	Canada	cULus
	Europe	CE, Low Voltage Directive, EN 60950 GS (power adapter) EN 60601 (medical), LUD

Compliance

United States



FCC - Class B

This equipment has been tested and found to comply with the limits for a Class B digital device, pursuant to part 15 of the FCC Rules. These limits are designed to provide reasonable protection against harmful interference in a residential installation. This equipment generates, uses, and can radiate radio frequency energy and, if not installed and used in accordance with the instructions, may cause harmful interference to radio communications. However, there is no guarantee that interference will not occur in a particular installation. If this equipment does cause harmful interference to radio or television reception, which can be determined by turning the equipment off and on, the user is encouraged to try to correct the interference by one or more of the following measures:

- Reorient or relocate the receiving antenna.
- Increase the separation between the equipment and receiver.
- Connect the equipment into an outlet on a circuit different from that to which the receiver is connected.
- Consult the dealer or an experienced radio/TV technician for help.

Any changes or modifications not expressly approved by the party responsible for compliance could void the user's authority to operate this equipment.

RF Radiation Exposure Statement

This equipment complies with FCC RF radiation exposure limits set forth for fixed indoor use only. This equipment should be installed and operated with a minimum distance of 38.5 centimeters (15.2 inches) between the radiator and your body for 2.4 GHz and 5 GHz operations. This transmitter must not be co-located or operating in conjunction with any other antenna or transmitter.

Radio Frequency Interference Requirements

This device is restricted to indoor use due to its operation in the 5.15 to 5.25 GHz frequency range. The FCC requires this product to be used indoors to reduce the potential for harmful interference to co-channel Mobile Satellite systems. High power radars are allocated as primary users of the 5.25 to 5.35 GHz and 5.65 to 5.85 GHz bands. These radar stations can cause interference with and/or damage this device.

Canada

This digital apparatus does not exceed the Class B limits for radio noise emissions from digital apparatus as set out in the interference-causing equipment standard entitled "Digital Apparatus," ICES-003 of the Department of Communications.

Cet appareil numérique respecte les limites de bruits radioélectriques applicables aux appareils numériques de Classe B prescrites dans la norme sur le matériel brouilleur: "Appareils Numériques," NMB-003 édictée par le ministère des Communications.

The use of this device operating either partially or completely outdoors may require the user to obtain a license for the system according to the Canadian regulations. For further information, contact your local Industry Canada office.

RSS-210

This device, when operated in the 5150-5250 MHz frequency range, is only for indoor use.



CAUTION: High power radars are allocated as primary users (meaning they have priority) in the 5250-5350 MHz and 5650-5850 MHz frequency ranges, and these radars could cause interference and/or damage to LE-LAN devices.

RSS-Gen

This device has been designed to operate with the antennas listed at [Table C-4 on page 37](#), and having a maximum gain of 15.0dBi for 2.4GHz and 14.0dBi for 5GHz. Antennas not included in this list or having a gain greater than 15.0dBi for 2.4GHz and 14.0dBi for 5GHz are strictly prohibited for use with this device. The required antenna impedance is 50 Ohms.

To reduce potential radio interference to other users, the antenna type and its gain should be so chosen that the equivalent isotropically radiated power (EIRP) is not more than that permitted for successful communication.

Operation is subject to the following two conditions: (1) this device may not cause interference, and (2) this device must accept any interference, including interference that may cause undesired operation of the device.

Japan

Indoor Restriction for 5GHz Frequency Range

この製品は法律により、5GHz 帯での屋外使用を禁じられています。

VCCI - Class B

この装置は、情報処理装置等電波障害自主規制協議会（VCCI）の基準に基づくクラスB情報技術装置です。この装置は、家庭環境で使用することを目的としていますが、この装置がラジオやテレビジョン受信機に近接して使用されると受信障害を引き起こすことがあります。

取り扱い説明書に従って正しい取り扱いをして下さい。

Korea

Class B Equipment (Household purpose info/telecommunication equipment)

As this equipment has undergone EMC registration for household purpose, this product can be used in any area including residential area.

B급 기기 (가정용 정보통신기기)

이 기기는 가정용으로 전자파적합등록을 한 기기로서 주거지역에서는 물론 모든 지역에서 사용할 수 있습니다.

Europe



WARNING: This is a Class B product. In a domestic environment, this product may cause radio interference in which case the user may be required to take adequate measures.

This product complies with Directive 1999/5/EC as well as with EN5022 Class B and EN5024 standards.

Taiwan

Low-power, radio-frequency devices must not be altered by changing the operating frequency, increasing emission power, adding external antennas, and changing other original design features and functions.

The operation of low-power, radio-frequency devices must not cause harmful interference, and that interference caused by the operation of authorized radio stations, by another intentional or unintentional radiator, by industrial, scientific, and medical (ISM) equipment, or by an incidental radiator must be accepted. If interference is caused, the user must immediately stop operating the low-power, radio-frequency device and not resume operation until all harmful interference is cleared.

TABLE C-2 OAW-AP80M 802.11 Specifications¹

Description	802.11a	802.11b/g
External Antenna	Alcatel offers a wide variety of detachable antenna types suitable for use with the OAW-AP80M. Please contact your local sales representative for details	
Frequency Band	<ul style="list-style-type: none"> ■ 5.150 ~ 5.250 GHz (channels country specific) ■ 5.250 ~ 5.350 GHz (ETSI) (channels country specific) ■ 5.470~ 5.725 GHz (channels country specific) ■ 5.725 ~ 5.825/5.850 GHz (Channels are country specific and in Taiwan 5ch is normal mode. Turbo mode is not supported.) <p>NOTE: Radio frequency band 5.150 ~ 5.725 GHz not supported in Taiwan</p>	<ul style="list-style-type: none"> ■ 2.4 ~ 2.4835 GHz (channels country specific)
Operating Channels	<ul style="list-style-type: none"> ■ US, Canada - 13 ■ ETSI - up to 19 ■ Japan - Disabled 	<ul style="list-style-type: none"> ■ US, Canada - 11 ■ ETSI - 13 ■ Japan - 13

TABLE C-2 OAW-AP80M 802.11 Specifications¹ (Continued)

Description	802.11a	802.11b/g
Radio Technology	Orthogonal Frequency Division Multiplexing (OFDM)	Direct Sequence Spread Spectrum (DSSS) Orthogonal Frequency Division Multiplexing (OFDM)
Modulation Type	BPSK, QPSK, 16-QAM, 64-QAM	CCK, BPSK, QPSK, 16-QAM, 64-QAM
Transmit Power	Configurable by system administrator/ professional installer	Configurable by system administrator/ professional installer
Media Access Control	CSMA/CA with ACK	CSMA/CA with ACK
Data Rates	6, 9, 12, 18, 24, 36, 48, 54 Mbps per channel	1, 2, 5.5, 6, 9, 11, 12, 18, 24, 36, 48, 54 Mbps per channel

1. Not all frequencies or frequency bands are available to all countries. Frequencies are enabled or disabled on a country-specific basis and are not configurable by the user.

TABLE C-3 OAW-AP80M Characteristics²

Description	
Maximum Clients	255
Multi-mode Radio Band	Selectable via software
Manageability:	<ul style="list-style-type: none"> ■ Management of all 802.11 parameters as AP ■ Network-wide AP management via: <ul style="list-style-type: none"> ● Telnet ● WEB GUI ● SNMP ■ Access point profiles ■ Management by: <ul style="list-style-type: none"> ● Geographical location ● BSSID ● Radio type ■ Encryption support (AP and Switch) <ul style="list-style-type: none"> ● 40-bit / 64-bit / 128-bit / 152-bit WEP, ■ TKIP, AES, WPA, WPA2
Encryption Support (AP and WLAN Switch)	40bit / 64bit / 128bit / 152bit WEP, TKIP, AES, WPA, WPA2.0
Physical (HxWxD):	<ul style="list-style-type: none"> ■ 198 x 198 x 70mm (7.80 x 7.80 x 2.76 in.) Weight 1.6 kilograms (3.53 pounds)
Part Numbers	<ul style="list-style-type: none"> ■ OAW-AP80M—Alcatel OAW-AP80M Access Point

TABLE C-3 OAW-AP80M Characteristics² (Continued)

Description	
Interfaces (Electrical):	<p>OAW-AP80M Interfaces</p> <ul style="list-style-type: none"> ■ 1 x 10/100 Base-TX auto-sensing Ethernet interface (IP67 8-pin male (pole) M12 circular DIN connector Au contacts): <ul style="list-style-type: none"> ● Auto-sensing MDI/MDX ● PoE 48V DC / 1.2A (30W) power over Ethernet (non-standard 802.3af) ● Integral lightening arrester ■ 1 x 2.4GHz N-type female antenna interface ■ 1 x 5GHz N-type female antenna interface ■ 1 x Electrical ground / Safety terminal ■ 1 x Integral ENET lightening arrester <p>Power Adapter Interfaces</p> <p>AP (Access Point) Port</p> <ul style="list-style-type: none"> ● 1 x 10/100 Base-TX auto-sensing Ethernet (RJ-45) network (AP) interface: <ul style="list-style-type: none"> - Auto-sensing MDI/MDX - PoE 48V DC / 1.2A power over Ethernet (non-standard 802.3af) <p>ENET (Network) Port</p> <ul style="list-style-type: none"> ● 1 x 10/100 Base-TX auto-sensing Ethernet (RJ-45) network (ENET), auto-sensing MDI/MDX Ethernet interface supplied with 8-pin DIN to RJ-45 CAT-5 Shielded Ethernet cable (50m / 164 ft)
Interfaces (Mechanical):	<ul style="list-style-type: none"> ■ 4 x Mounting Bracket Hex Screw Mounting Points ■ Ruggedized wall, pole or mast mount hardware provided (articulating in horizontal and vertical planes)
Visual Indicators (LEDs)	<ul style="list-style-type: none"> ■ Ready -- Power on/off (provided on Power Injector)

TABLE C-3 OAW-AP80M Characteristics² (Continued)

Description	
Power Requirements	<ul style="list-style-type: none"> ■ Access Point power draw: 48 VDC, 1.2 A, (30W maximum) Power over Ethernet (non-standard 802.3af) ■ External Power Injector, auto-sensing 100-240V AC Input, 1.5A. Output 48 VDC, 1.2 A (30W) provided
Output Power	100 mW maximum (or lower as configured on the OmniAccess WLAN Switch to comply with local regulatory requirements)
Environmental:	<p>OAW-AP80M</p> <ul style="list-style-type: none"> ■ Temperature: <ul style="list-style-type: none"> Operating: -30 to 55 °C (-22 to 131 °F) Storage: -40 to 80°C (-40 to 176 °F) ■ Humidity 0% to 95% (non-condensing) ■ Survival Wind Speed: 201Km/hr (125 MPH) ■ Altitude 4,572 m (15,000 feet) maximum <p>External Power Adapter</p> <ul style="list-style-type: none"> ■ AC Power: <ul style="list-style-type: none"> AC: 90VAC to 240VAC, auto-sensing input voltage, 1.5A @ 110VAC input current, 47-63 Hz input frequency ■ DC Power: <ul style="list-style-type: none"> 48VDC output voltage, 1.2A output current ■ Temperature: <ul style="list-style-type: none"> Operating: 0 to 40 °C (32 to 104°F) Storage: -20 to 70°C (-4 to 158 °F) ■ Humidity 15% to 85% RH ■ Altitude 4,572 m (15,000 feet) maximum
Standards Compliance	<ul style="list-style-type: none"> ■ Ethernet IEEE 802.3 / IEEE 802.3u ■ Wireless IEEE 802.11a/b/g ■ RFC 2516 PPP over Ethernet

2. The maximum output power at permitted operating frequencies is preset by country and cannot be increased by the user.

OAW-AP80M Detachable Antennas

The follow detachable antennas are supported by the OAW-AP80M.

TABLE C-4 Detachable Antennas

Part Number	Description	Vendor
AP-ANT-80	2.4Ghz / 8.0dBi High-Gain, Omni-Directional Cylindrical Antenna. N-Type Connector	Indoor / Outdoor Use. Cushcraft Part # S2406BP36NM
AP-ANT-81	2.4Ghz / 8.0dBi High-Gain, 60° Sector Directional Antenna. N-Type Connector	Indoor / Outdoor Use. Cushcraft Part # S2408PA36NM
AP-ANT-82	2.4Ghz / 12.0dBi High-Gain, Wide-Angle 90° Directional Sector Antenna. N-Type Connector	Indoor / Outdoor Use. Cushcraft Part # S2401290PA36NM
AP-ANT-83	2.4Ghz / 7.0dBi Wide-Angle 90° Directional Sector Antenna. N-Type Connector	Indoor / Outdoor Use. Cushcraft Part # S240790PA36NM
Not certified for use in Japan.		
AP-ANT-84	2.4Ghz / 5.0dBi Wide-Angle 135° Directional Antenna. N-Type Connector	Indoor / Outdoor Use. Cushcraft Part # SR24135DA36NM
Not certified for use in Japan.		
AP-ANT-85	2.4Ghz / 15.0dBi High-Gain, Directional Panel Antenna. N-Type Connector	Indoor / Outdoor Use. Cushcraft Part # S24015P36NM
Not certified for use in Japan.		
AP-ANT-86	5.10Ghz-5.90Ghz / 10.0dBi High-Gain, Omni-Directional Cylindrical Antenna. N-Type Connector	Indoor / Outdoor Use. Cushcraft Part # S5158WBP36NM
Not certified for use in Japan.		
AP-ANT-87	2.4Ghz-2.5Ghz / 4.90Ghz-5.99Ghz / 7.0dBi Dual-Band, High-Gain, 60° Sector Antenna. N-Type Connector	Indoor / Outdoor Use. Cushcraft Part # S24497P36NM
Not certified for use in Japan.		

TABLE C-4 Detachable Antennas (Continued)

Part Number	Description	Vendor
AP-ANT-88	4.90Ghz-5.90Ghz / 10.5dBi Wide-Angle 120° Directional Sector Antenna. N-Type Connector	Indoor / Outdoor Use. Cushcraft Part # SR49120DA36NM
Not certified for use in Japan.		
AP-ANT-89	5Ghz / 14.0dBi High-Gain, Directional Panel Antenna. N-Type Connector	Indoor / Outdoor Use. Cushcraft Part # S51514WP36NM
Not certified for use in Japan.		

Proper Disposal of Alcatel Equipment

Waste of Electrical and Electronic Equipment

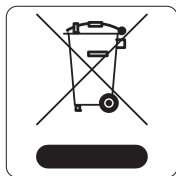

Aruba products at end of life are subject to separate collection and treatment in the EU Member States, Norway, and Switzerland and therefore are marked with the symbol shown at the left (crossed-out wheelie bin). The treatment applied at end of life of these products in these countries shall comply with the applicable national laws of countries implementing Directive 2002/96EC on Waste of Electrical and Electronic Equipment (WEEE).

European Union RoHS



Aruba products also comply with the EU Restriction of Hazardous Substances Directive 2002/95/EC (RoHS). EU RoHS restricts the use of specific hazardous materials in the manufacture of electrical and electronic equipment. Specifically, restricted materials under the RoHS Directive are Lead (including Solder used in printed circuit assemblies), Cadmium, Mercury, Hexavalent Chromium, and Bromine. Some Aruba products are subject to the exemptions listed in RoHS Directive Annex 7 (Lead in solder used in printed circuit assemblies). Products and packaging will be marked with the "RoHS" label shown at the left indicating conformance to this Directive.

China RoHS



Aruba products also comply with China environmental declaration requirements and are labeled with the "EFUP 50" label shown at the left.

有毒有害物质声明

Hazardous Materials Declaration

部件名称 (Parts)	有毒有害物质或元素 (Hazardous Substances)					
	铅 Lead (Pb)	汞 Mercury (Hg)	镉 Cadmium (Cd)	六价铬 Chromium VI Compounds (Cr ⁶⁺)	多溴联苯 Polybrominated Biphenyls (PBB)	多溴二苯醚 Polybrominated Diphenyl Ether (PBDE)
电路板 PCA Board	X	O	O	O	O	O
机械组件 Mechanical Subassembly	X	O	O	O	O	O
O: 表示该有毒有害物质在该部件所有均质材料中的含量均在SJ/T11363-2006标准规定的限量要求以下。 This component does not contain this hazardous substance above the maximum concentration values in homogeneous materials specified in the SJ/T11363-2006 Industry Standard.						
X: 表示该有毒有害物质至少在该部件的某一均质材料中的含量超出SJ/T11363-2006标准规定的限量要求。 This component does contain this hazardous substance above the maximum concentration values in homogeneous materials specified in the SJ/T11363-2006 Industry Standard.						
对销售之日的所售产品, 本表显示, 供应链的电子产品信息产品可能包含这些物质。 This table shows where these substances may be found in the supply chain of electronic information products, as of the date of sale of the enclosed product.						
此标志为针对所涉及产品的环保使用期标志。 某些零部件会有一个不同的环保使用期(例如, 电池单元模块)贴在其产品上。 此环保使用期限只适用于产品是在产品手册中所规定的条件下工作。 The Environment- Friendly Use Period (EFUP) for all enclosed products and their parts are per the symbol shown here. The Environment- Friendly Use Period is valid only when the product is operated under the conditions defined in the product manual.						

Related Documents

The following items are part of the complete documentation for the Alcatel system:

- *Alcatel Quick Start Guide*
- *Alcatel OAW-AP80M Access Point Installation Guide* (this document)
- *Alcatel OmniAccess WLAN Switch Installation Guide*
- *AOS-W User Guide*

For the current versions of these manuals, or to obtain the latest product release notes, visit the support section of our Web site (see [page 40](#)).

Contacting Alcatel

To contact Alcatel, refer to the information below:

Address

26801 West Agoura Road
Calabasas, CA 91301

Phone

VOICE	(818) 880-3500
FAX	(818) 880-3505

Email

info@ind.alcatel.com

Website

<http://www.alcatel.com/enterprise/en/index.html>

Support

Phone:

US Toll Free:	(800) 995-2696
International:	(818) 878-4507

Email:

support@ind.alcatel.com

Website:

<http://eservice.ind.alcatel.com>